

4

3

2

1

F

F

E

E

D

D

C

C

B

B

A

A

Schutzvermerk ISO 16016 beachten.
 Use of the document / contents is forbidden
 without expressed written authority. All rights reserved.
 ECOSPHERE GmbH & Co. KG

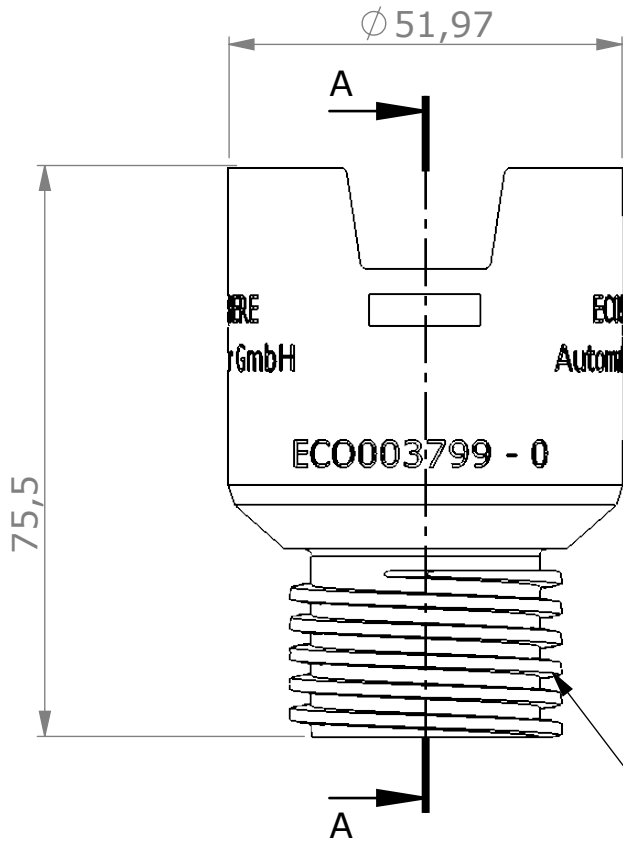

Anschluss für Kärcher
Clip Anschluss DN35

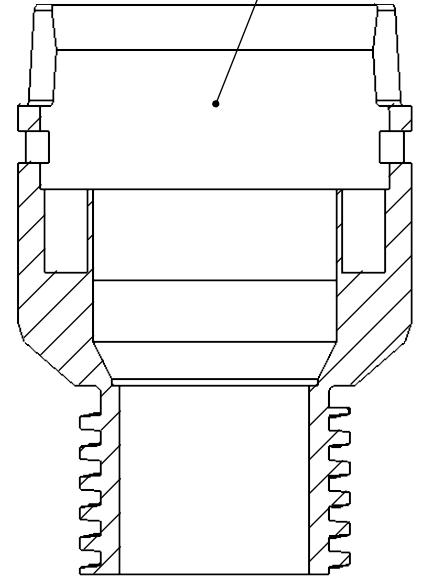

Anschlussgewinde für
OnRobot Sander

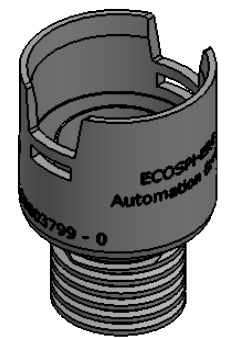
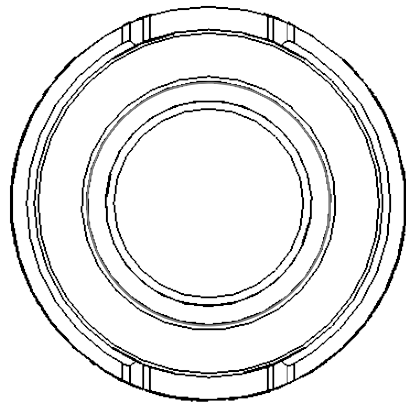

Projektionsmethode 1 nach DIN ISO 5456
First Angle Projection According to ISO 5456

Werkstoff / Material		Änderungstext / Modification Text		Kommt vor / Amends			
InitialMaterial				0x			
Oberfläche/ surface		ERPID/PDMID: / /		Gewicht / Weight			
				0.04 kg			
Allgemeintoleranzen / General Tolerance				 ECOSPHERE® GmbH & Co. KG			
Bearbeitung / Created by		Datum / Date (dd.mm.yyyy)				Abteilung / Department	
Achim Schultes		10.01.2024				R&D	
Benennung / Description				Reifegrad / Status			
Adapter OnRobot Sander Kärcher				In Arbeit			
				Sachnummer/Part No. - Äz/Rev.		Maßstab/ Scale	
ECO003799		- 0		1:2			
Dokumententyp / Document Type		SWX A4		Ersatz für / Repl. for			
		Seite / Page		1 von / of 1			

4

3

2

1