

Schutzvermerk ISO 16016 beachten.
 Use of the document / contents is forbidden
 without expressed written authority. All rights reserved.
 ECOSPHERE GmbH & Co. KG

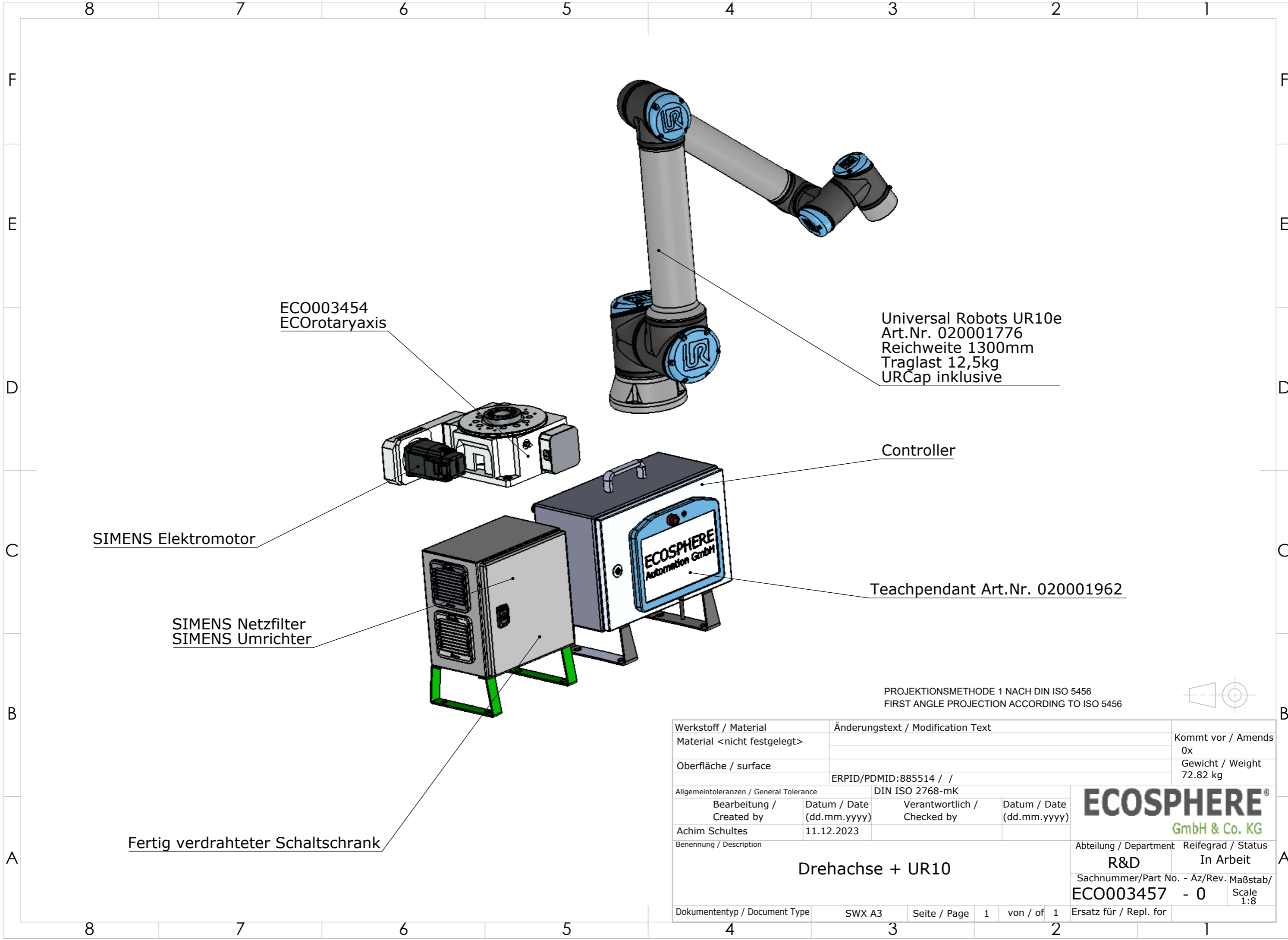

ECO003454
ECOrotaryaxis

Universal Robots UR10e
 Art.Nr. 020001776
 Reichweite 1300mm
 Traglast 12,5kg
 URCap inklusive

Controller

SIMENS Elektromotor

Teachpendant Art.Nr. 020001962

SIMENS Netzfilter
SIMENS Umrichter

Fertig verdrahteter Schaltschrank

PROJEKTIONSMETHODE 1 NACH DIN ISO 5456
 FIRST ANGLE PROJECTION ACCORDING TO ISO 5456



Werkstoff / Material		Änderungstext / Modification Text		Kommt vor / Amends	
Material <nicht festgelegt>				0x	
Oberfläche / surface		ERPID/PDMID:885514 / /		Gewicht / Weight	
				72.82 kg	
Allgemeintoleranzen / General Tolerance			DIN ISO 2768-mK		
Bearbeitung / Created by	Datum / Date (dd.mm.yyyy)	Verantwortlich / Checked by	Datum / Date (dd.mm.yyyy)		
Achim Schultes	11.12.2023				
Benennung / Description				Abteilung / Department	
Drehachse + UR10				R&D	
				Reifegrad / Status	
				In Arbeit	
				Sachnummer/Part No. - Äz/Rev.	
				ECO003457 - 0	
				Maßstab/ Scale	
				1:8	
Dokumententyp / Document Type		SWX A3	Seite / Page	1 von / of 1	Ersatz für / Repl. for
					1