

Schutzvermerk ISO 16016 beachten.  
 Use of the document / contents is forbidden  
 without expressed written authority. All rights reserved.  
 ECOSPHERE GmbH & Co. KG

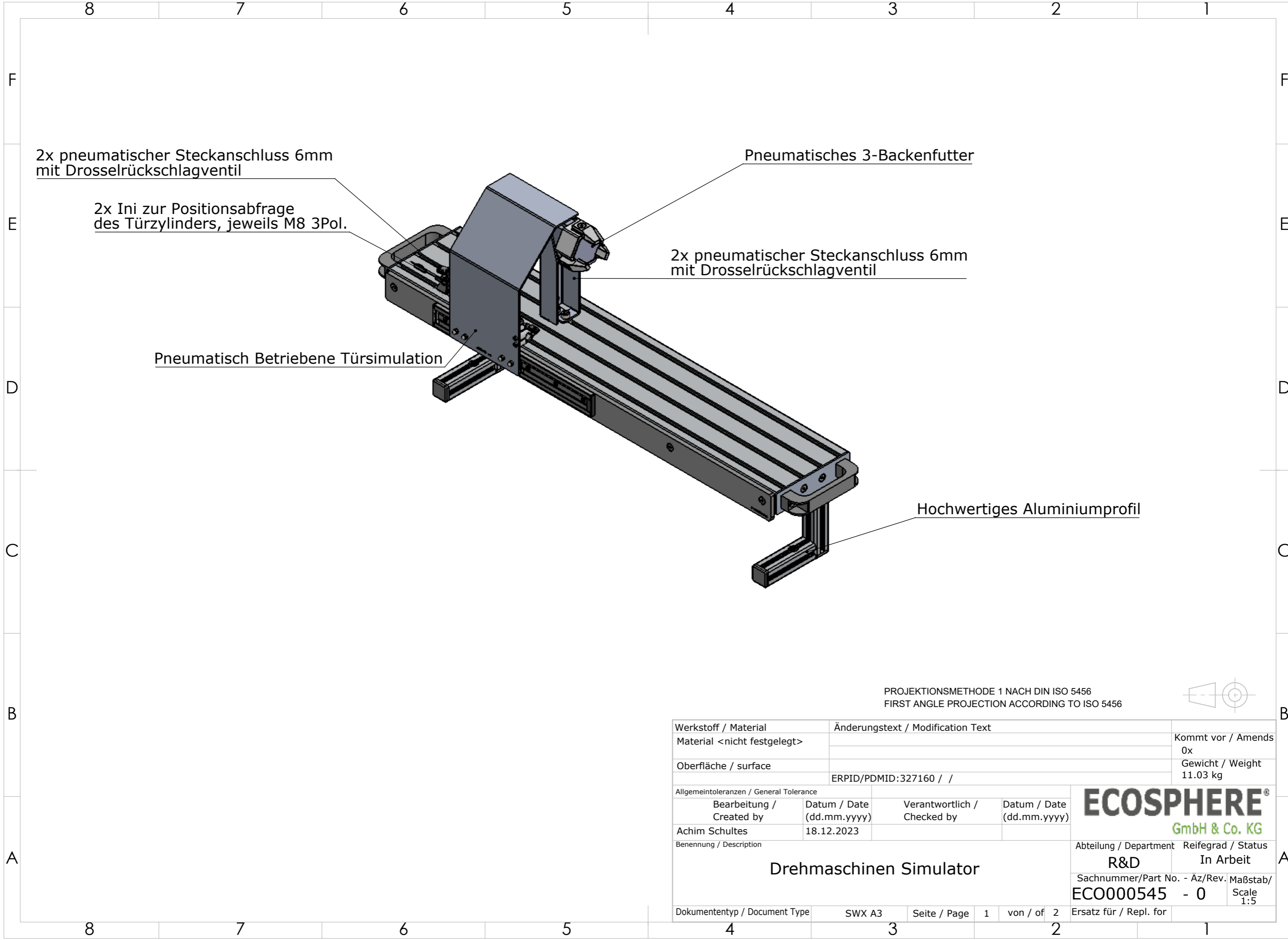

2x pneumatischer Steckanschluss 6mm mit Drosselrückschlagventil

2x Ini zur Positionsabfrage des Türzylinders, jeweils M8 3Pol.

Pneumatisches 3-Backenfutter

2x pneumatischer Steckanschluss 6mm mit Drosselrückschlagventil

Pneumatisch Betriebene Türsimulation

Hochwertiges Aluminiumprofil

PROJEKTIONSMETHODE 1 NACH DIN ISO 5456  
 FIRST ANGLE PROJECTION ACCORDING TO ISO 5456



Werkstoff / Material		Änderungstext / Modification Text		Kommt vor / Amends	
Material <nicht festgelegt>				0x	
Oberfläche / surface		ERPID/PDMID:327160 / /		Gewicht / Weight	
				11.03 kg	
Allgemeintoleranzen / General Tolerance					
Bearbeitung / Created by	Datum / Date (dd.mm.yyyy)	Verantwortlich / Checked by	Datum / Date (dd.mm.yyyy)	<b>ECOSPHERE<sup>®</sup></b> GmbH & Co. KG	
Achim Schultes	18.12.2023				
Benennung / Description				Abteilung / Department	Reifegrad / Status
Drehmaschinen Simulator				R&D	In Arbeit
				Sachnummer/Part No. - Äz/Rev.	
ECO000545 - 0		1:5			
Dokumententyp / Document Type		SWX A3	Seite / Page	1 von / of 2	Ersatz für / Repl. for
					1

Schutzvermerk ISO 16016 beachten.  
 Use of the document / contents is forbidden  
 without expressed written authority. All rights reserved.  
 ECOSPHERE GmbH & Co. KG

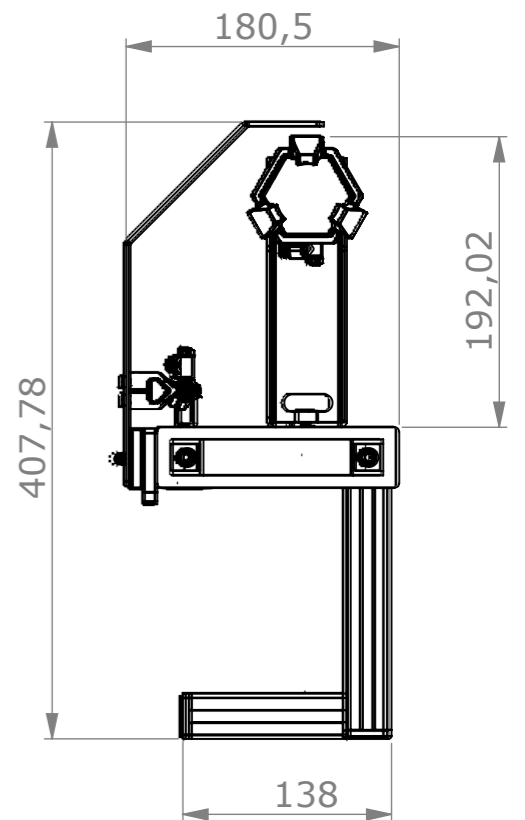
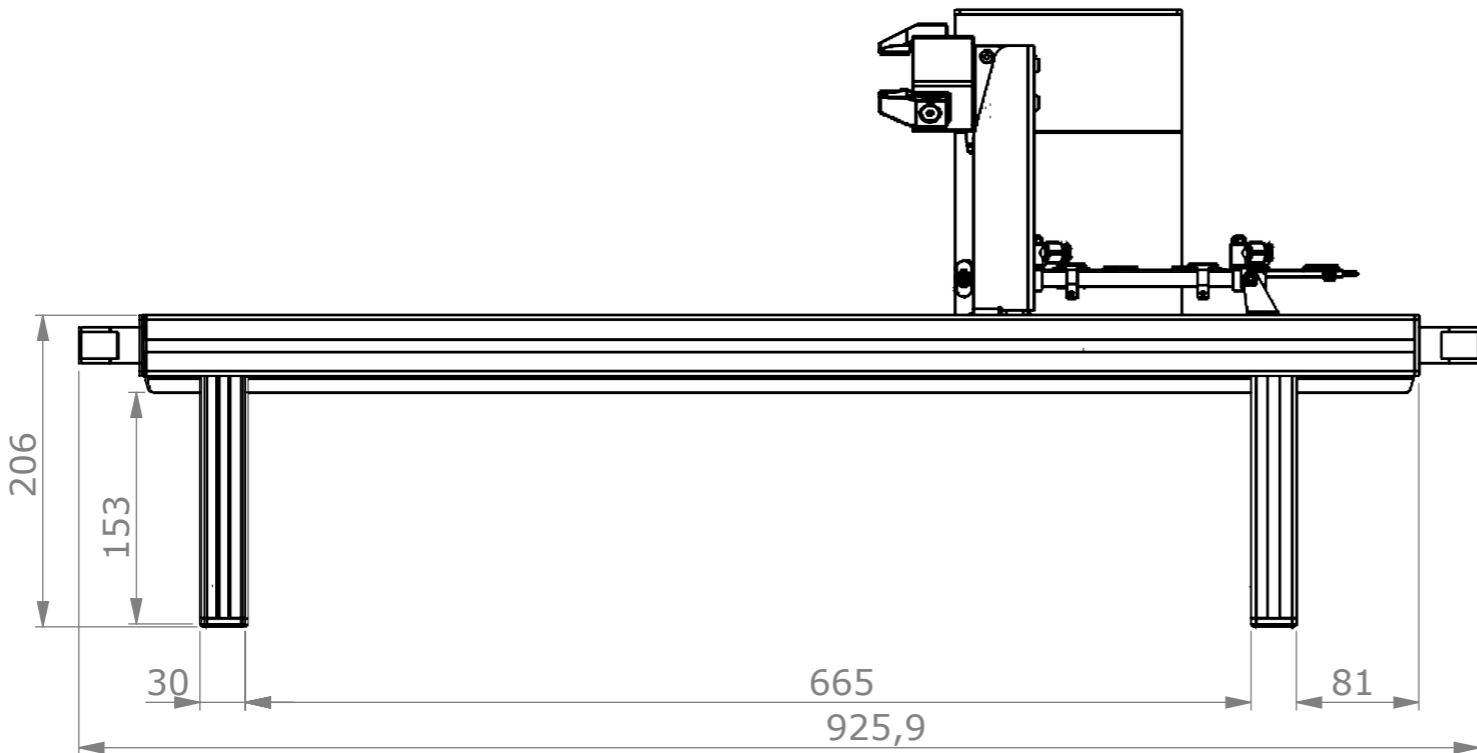

PROJEKTIONSMETHODE 1 NACH DIN ISO 5456  
 FIRST ANGLE PROJECTION ACCORDING TO ISO 5456



Werkstoff / Material		Änderungstext / Modification Text		Kommt vor / Amends 0x
Material <nicht festgelegt>				
Oberfläche / surface		ERPID/PDMID:327160 / /		Gewicht / Weight 11.03 kg
Allgemeintoleranzen / General Tolerance				
Bearbeitung / Created by	Datum / Date (dd.mm.yyyy)	Verantwortlich / Checked by	Datum / Date (dd.mm.yyyy)	<b>ECOSPHERE®</b> GmbH & Co. KG
Achim Schultes	10.01.2024			
Benennung / Description			Abteilung / Department	Reifegrad / Status
Drehmaschinen Simulator			R&D	In Arbeit
			Sachnummer/Part No. - Äz/Rev. Maßstab/ ECO000545 - 0 Scale 1:5	
Dokumententyp / Document Type	SWX A3	Seite / Page	2 von / of 2	Ersatz für / Repl. for

